

ART. B104WF Batteria lavabo / Washbasin / Lavabo 3 trous / Waschtischarmatur / Lavabo 3 piezas

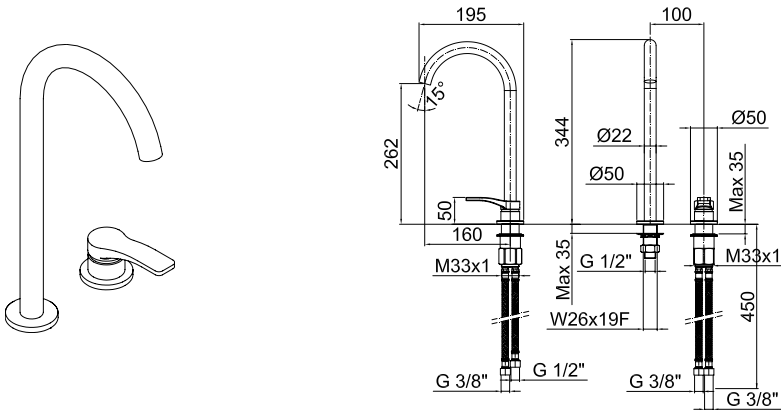

ART. B106WF Batteria lavabo / Washbasin / Lavabo 3 trous / Waschtischarmatur / Lavabo 3 piezas

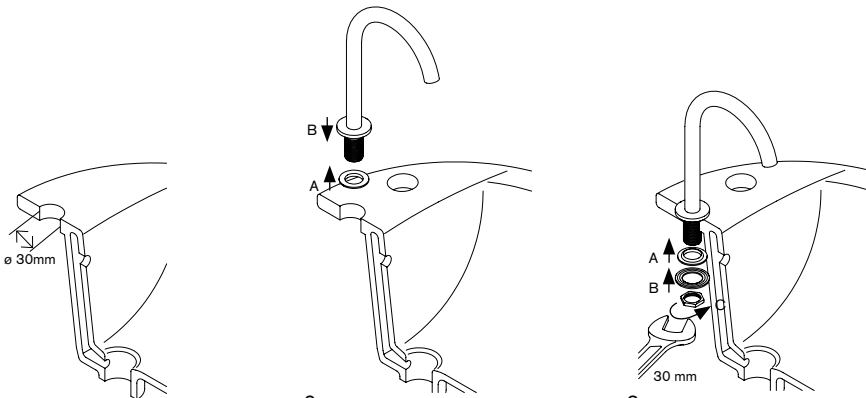

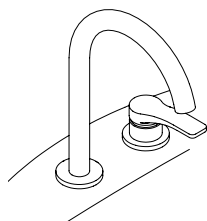
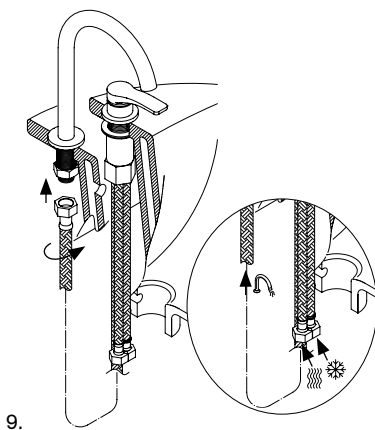
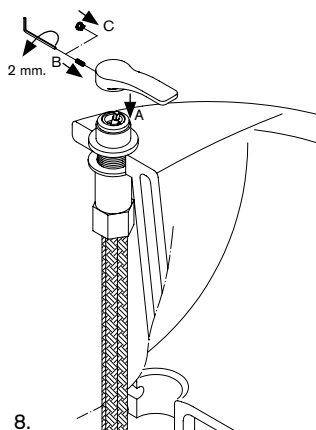
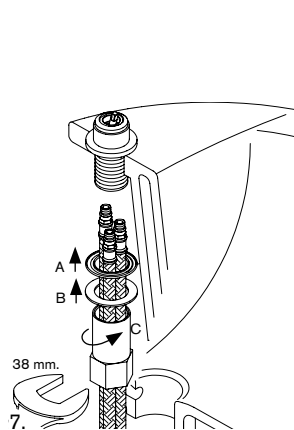
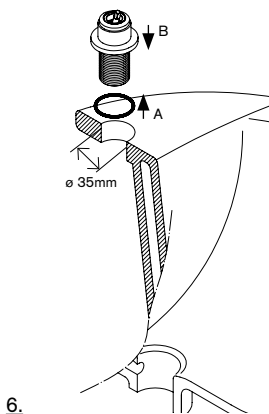
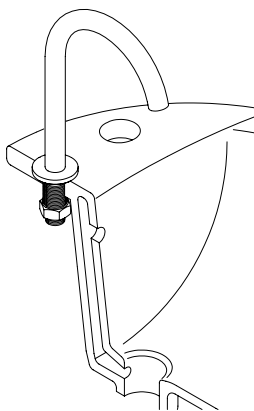
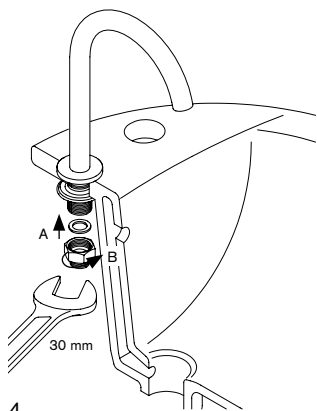

Regolazioni / Adjustments / Ajustements / Anpassungen / Ajustes

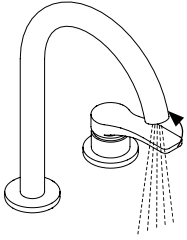

1.

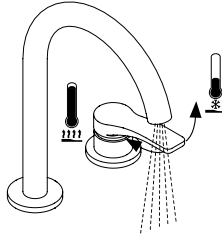

2.

Sostituzione cartuccia / Cartridge replacement / Remplacement de la cartouche  
 Auswechseln der Kartusche / Sustitucion del cartucho  
 Per art. B104WF - B106WF

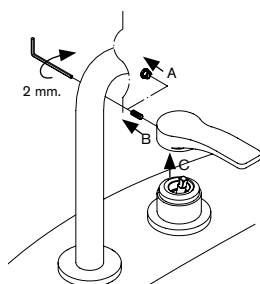

1.

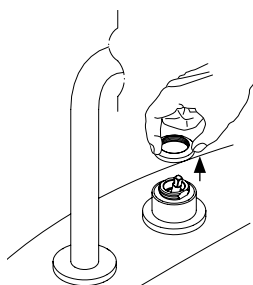

2.

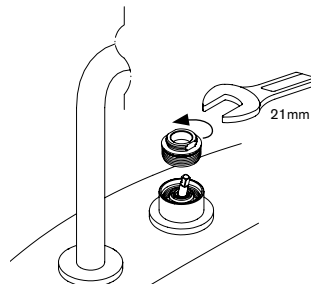

3.

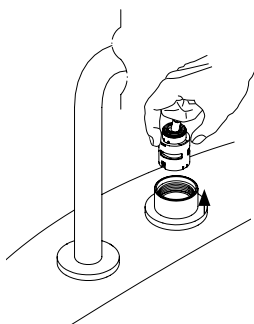

4.

Rimontare seguendo il procedimento inverso (4-3-2-1). Serrare la ghiera (3) con una coppia di 10÷12 Nm.

Replace following the instructions in reverse order (4-3-2-1). Tighten the ring (3) with a pair of 10÷12 Nm.

Re-installer au contraire du procédé (4-3-2-1). Serrer l'écrou (3) avec une paire de 10÷12 Nm.

Die umgekehrte Vorgehensweise folgen um die Teil wieder zu installieren (4-3-2-1). Ziehen Sie die Mutter (3) mit einem Paar von 10÷12 Nm.

Colocar según el procedimiento inverso (4-3-2-1). Apretar la tuerca (3) con un par de 10÷12 Nm.