

ART. 4711B

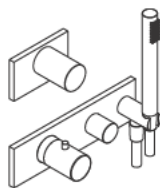

ART. 4712B

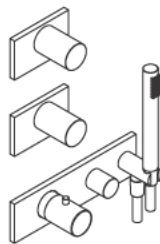

ART. 4713B

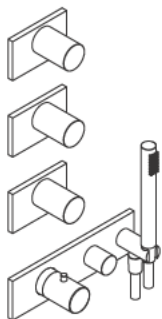

ART. 4714B



ART. 4790B

Utensili necessari / Tools needed / Outils nécessaires / Werkzeuge benötigt / Instrumentos necesarios

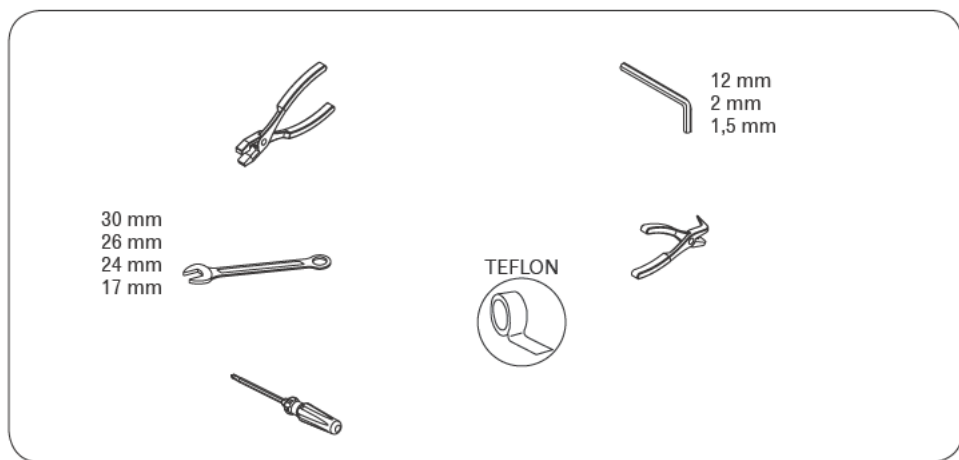

Indice / Index / Index / Übersicht / Índice

4711B Parte esterna / External pieces / Parties externes / Up-Teil / Parte externa,	4
4712B Parte esterna / External pieces / Parties externes / Up-Teil / Parte externa,	8
4713B Parte esterna / External pieces / Parties externes / Up-Teil / Parte externa,	12
4714B Parte esterna / External pieces / Parties externes / Up-Teil / Parte externa,	16
4790B Parte esterna / External pieces / Parties externes / Up-Teil / Parte externa,	20
Sostituzione cartuccia / Cartridge replacement / Remplacement de la cartouche / Auswechseln der Kartusche / Sustitucion del cartucho,	23
Sostituzione vitone / Bolt replacement / Remplacement de la tête / Oberteilsersetzung / Sustitucion rosca de extrusion,	27
Pulizia valvola di non ritorno / Cleaning backflow prevention valve / Nettoyage clapet anti-rétour / Reinigung Rückschlagventil / Limpieza válvula anti-retorno,	28
Montaggio prolunghe da 20 mm. / Mounting 20 mm extension / Montage rallonges 20 mm / Montage 20 mm Verlängerung / Montaje de 20 mm de pronologaciones,	29
Montaggio prolunghe da 20 mm. rubinetto doccetta / Mounting 20 mm extension built-in handshower / Montage rallonges 20 mm robinet de douche / Montage 20 mm Verlängerung Brausebatterie / Montaje de 20 mm de pronologaciones,	33
Montaggio prolunghe da 35 mm. / Mounting 35 mm extension / Montage rallonges 35 mm / Montage 35 mm Verlängerung / Montaje de 35 mm de pronologaciones,	34
Montaggio prolunghe da 35 mm. rubinetto doccetta / Mounting 35 mm extension built-in handshower / Montage rallonges 35 mm robinet de douche / Montage 35 mm Verlängerung Brausebatterie / Montaje de 35 mm de pronologaciones,	38
Montaggio prolunghe rubinetto d'arresto / Mounting extension stopcock / Montage rallonges tabez les extensions arresto / Montage Verlängerung Hahnverlängerungen / Montaje de pronologaciones arresto,	39
Dati tecnici / Technical data / Caractéristiques techniques / Technische Daten / Datos Técnicos,	40

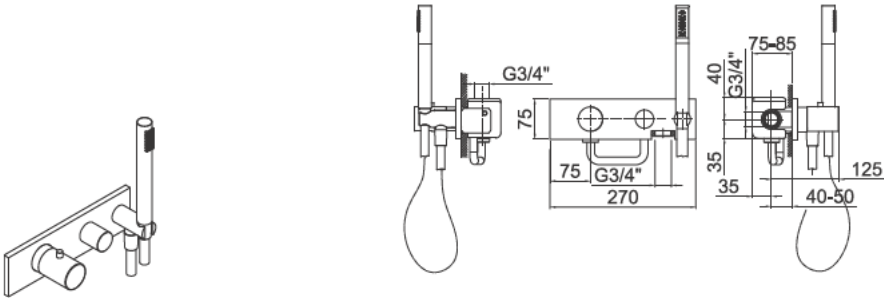

ART. 4711B Parte esterna / External pieces / Parties externes / Up-Teil / Parte externa

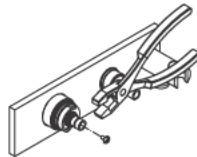

- Durante il montaggio e la manutenzione si consiglia di non ruotare il perno della cartuccia. Se necessita ristabilire la posizione di 38° C effettuare le procedure di pag. 25-26.
- During assembly and maintenance, it is advisable not to turn the cartridge pivot. If it is necessary to reposition to 38 °C, follow the procedure on page 25-26.
- Pendant le montage et l'entretien, il est conseillé de ne pas tourner le pivot de la cartouche. Si nécessaire, rétablir la position de 38°C. Effectuer les procédures indiquées à la p. 25-26.
- Es wird geraten, den Kartuschenstift während des Einbaus und der Instandhaltung nicht zu drehen. Sollte es nötig sein, auf 38 °C wieder zu positionieren, siehe die Prozedur auf Seite 25-26.
- Durante el montaje y mantenimiento se aconseja no girar el perno del cartucho. Si necesita restablecer la posición de 38°C llevar a cabo el procedimiento de la pág. 25-26.

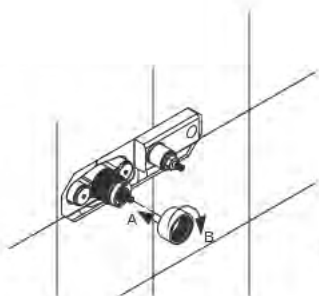

1.

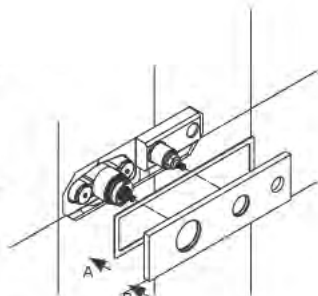

2.

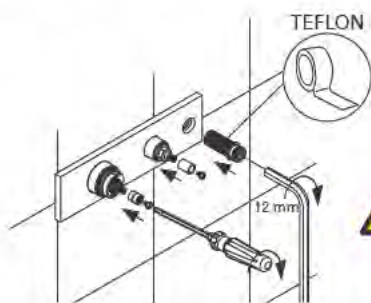

3.



- Quando si avvita l'adattatore cartuccia fare attenzione a non far ruotare l'asta della cartuccia (vedi pag. 4).
- When screwing on the cartridge adapter take care not to rotate the rod of the cartridge (see page 4).
- Veiller, en vissant l'adaptateur de la cartouche, à ne pas faire tourner la tige de la cartouche (voir p. 4).
- Beim Anschrauben des Kartuschenadapters sollte der Kartuschenstab nicht rotiert werden (siehe Seite 4).
- Cuando se atomilla el adaptador del cartucho tener la precaución de no girar el asta del cartucho (ver pag.4).

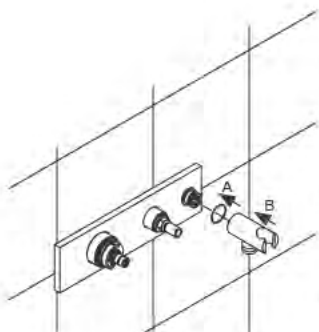

4.

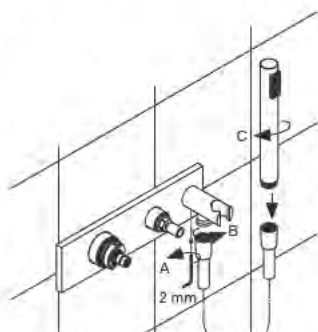

5.

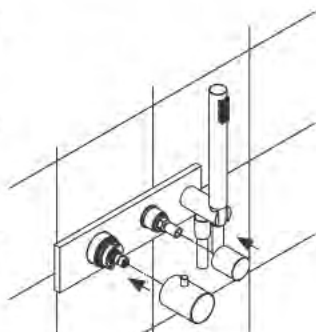

6.

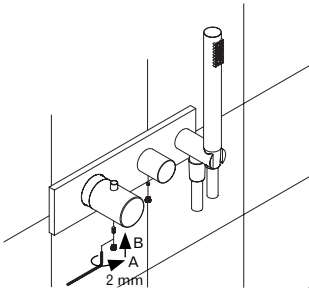

7.

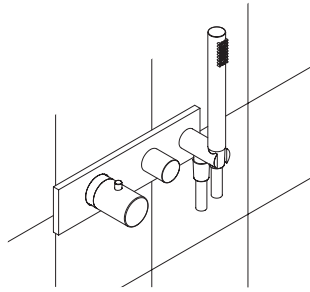

8.

Regolazioni / Adjustments / Ajustements / Anpassungen / Ajustes

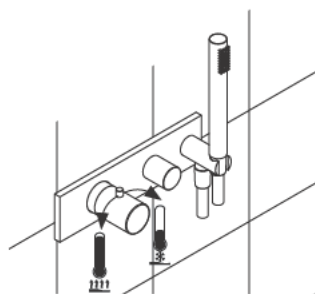

1.

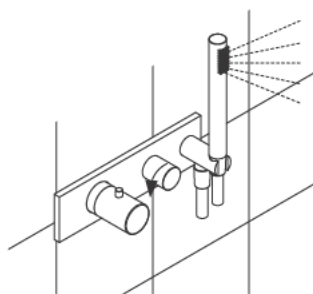

2.

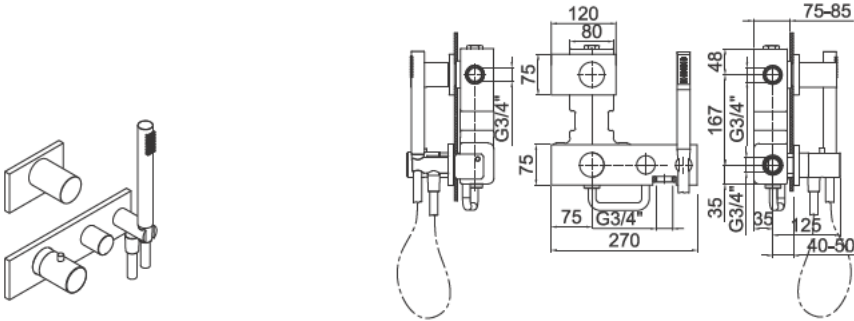

ART. 4712B Parte esterna / External pieces / Parties externes / Up-Teil / Parte externa

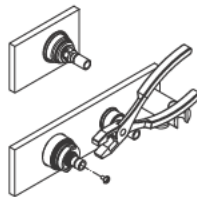

- Durante il montaggio e la manutenzione si consiglia di non ruotare il perno della cartuccia. Se necessita ristabilire la posizione di 38° C effettuare le procedure di pag. 25-26.
- During assembly and maintenance, it is advisable not to turn the cartridge pivot. If it is necessary to reposition to 38 °C, follow the procedure on page 25-26.
- Pendant le montage et l'entretien, il est conseillé de ne pas tourner le pivot de la cartouche. Si nécessaire, rétablir la position de 38°C. Effectuer les procédures indiquées à la p. 25-26.
- Es wird geraten, den Kartuschenstift während des Einbaus und der Instandhaltung nicht zu drehen. Sollte es nötig sein, auf 38 °C wieder zu positionieren, siehe die Prozedur auf Seite 25-26.
- Durante el montaje y mantenimiento se aconseja no girar el perno del cartucho. Si necesita restablecer la posición de 38°C llevar a cabo el procedimiento de la pág. 25-26.

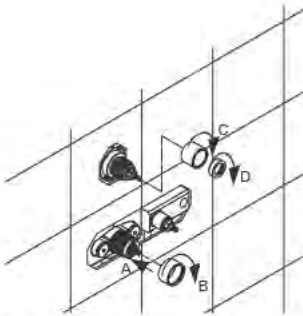

1.

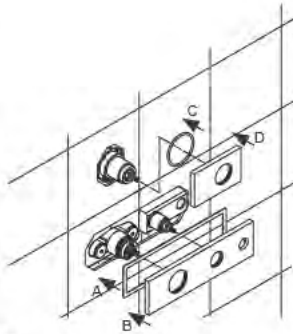

2.

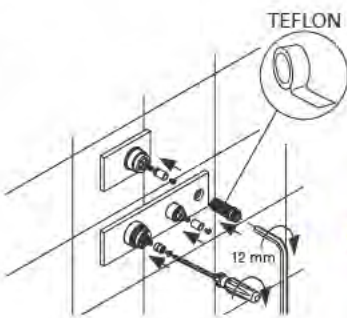

3.



- Quando si avvita l'adattatore cartuccia fare attenzione a non far ruotare l'asta della cartuccia (vedi pag. 8).
- When screwing on the cartridge adapter take care not to rotate the rod of the cartridge (see page 8).
- Veiller, en vissant l'adaptateur de la cartouche, à ne pas faire tourner la tige de la cartouche (voir p. 8).
- Beim Anschrauben des Kartuschenadapters sollte der Kartuschenstab nicht rotiert werden (siehe Seite 8).
- Cuando se atornilla el adaptador del cartucho tener la precaución de no girar el asta del cartucho (ver pag. 8).

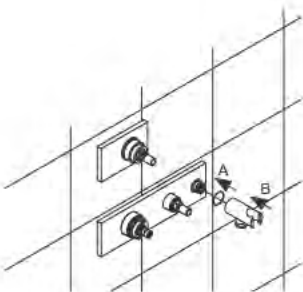

4.

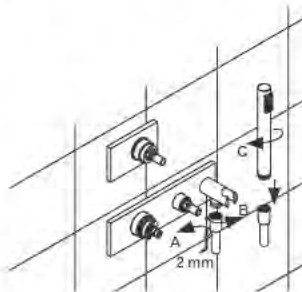

5.

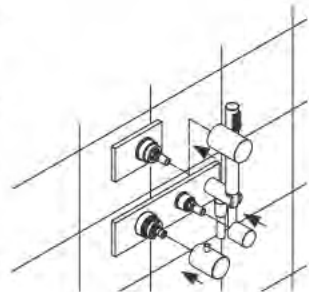

6.

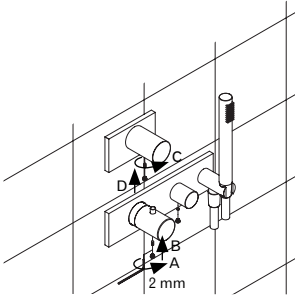

7.

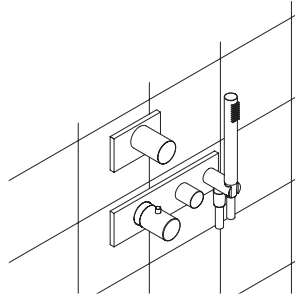

8.

Regolazioni / Adjustments / Ajustements / Anpassungen / Ajustes

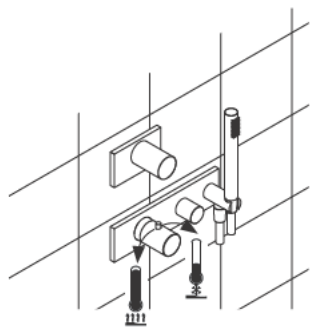

1.

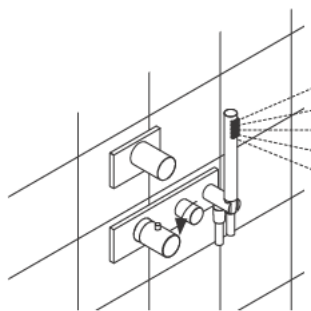

2.

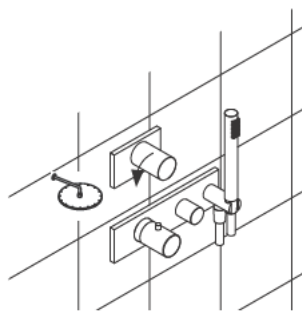

3.

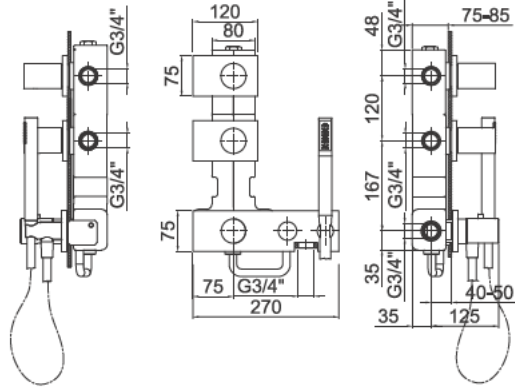
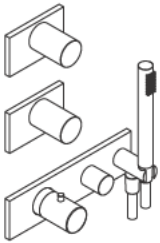

ART. 4713B Parte esterna / External pieces / Parties externes / Up-Teil / Parte externa

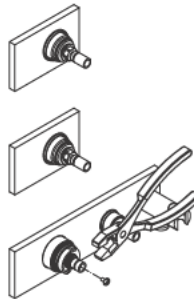

- Durante il montaggio e la manutenzione si consiglia di non ruotare il perno della cartuccia. Se necessita ristabilire la posizione di 38° C effettuare le procedure di pag. 25-26.
- During assembly and maintenance, it is advisable not to turn the cartridge pivot. If it is necessary to reposition to 38 °C, follow the procedure on page 25-26.
- Pendant le montage et l'entretien, il est conseillé de ne pas tourner le pivot de la cartouche. Si nécessaire, rétablir la position de 38°C. Effectuer les procédures indiquées à la p. 25-26.
- Es wird geraten, den Kartuschenstift während des Einbaus und der Instandhaltung nicht zu drehen. Sollte es nötig sein, auf 38 °C wieder zu positionieren, siehe die Prozedur auf Seite 25-26.
- Durante el montaje y mantenimiento se aconseja no girar el perno del cartucho. Si necesita restablecer la posición de 38°C llevar a cabo el procedimiento de la pág. 25-26.

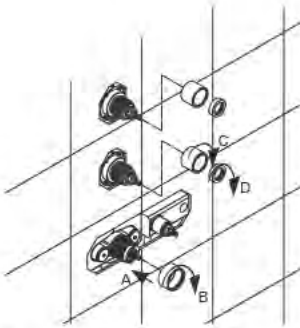

1.

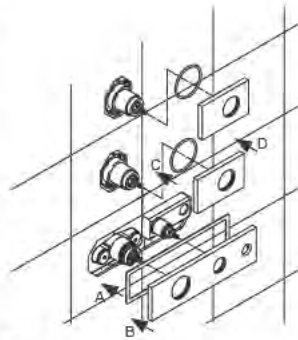

2.

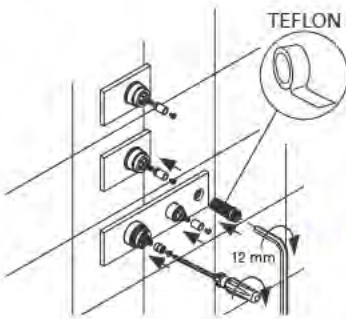

3.



- Quando si avvita l'adattatore cartuccia fare attenzione a non far ruotare l'asta della cartuccia (vedi pag. 12).
- When screwing on the cartridge adapter take care not to rotate the rod of the cartridge (see page 12).
- Veiller, en vissant l'adaptateur de la cartouche, à ne pas faire tourner la tige de la cartouche (voir p. 12).
- Beim Anschrauben des Kartuschenadapters sollte der Kartuschenstab nicht rotiert werden (siehe Seite 12).
- Cuando se atornilla el adaptador del cartucho tener la precaución de no girar el asta del cartucho (ver pag. 12).

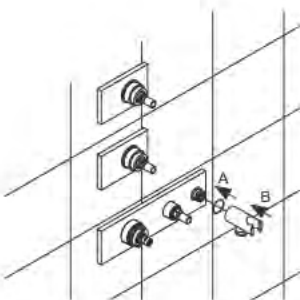

4.

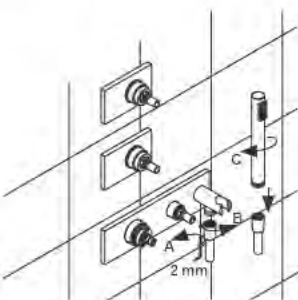

5.

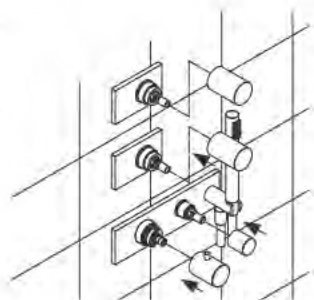

6.

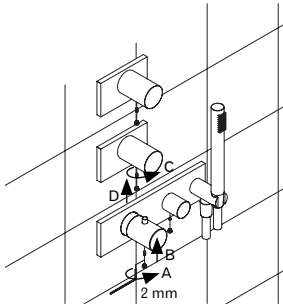

7.

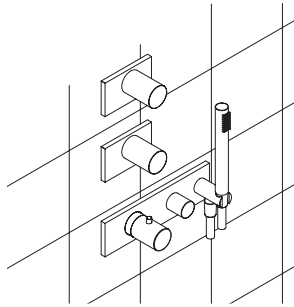

8.

Regolazioni / Adjustments / Ajustements / Anpassungen / Adjustas

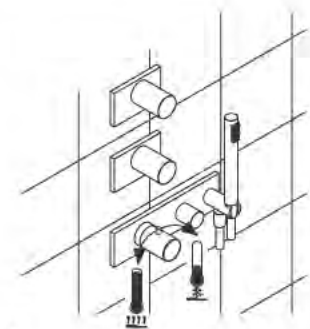

1.

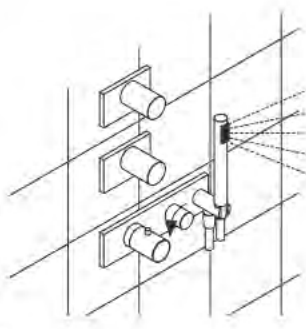

2.

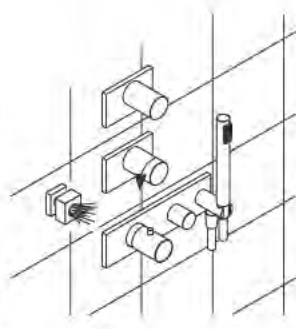

3.

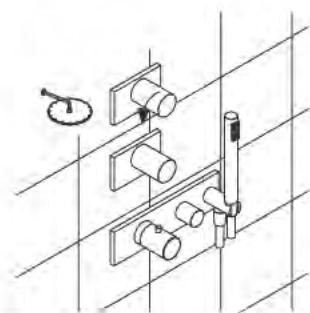

4.

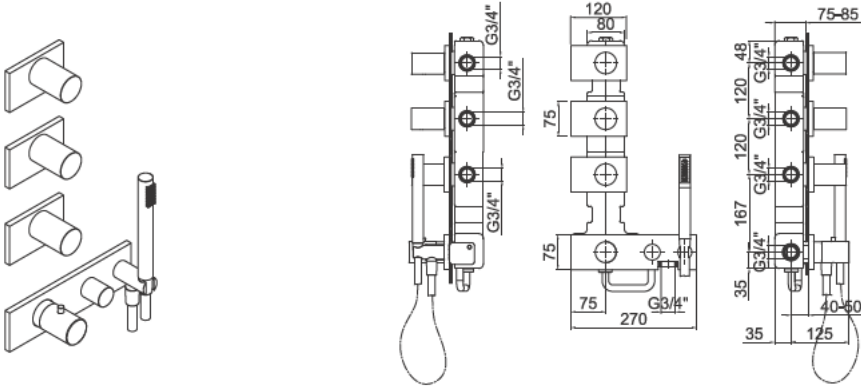

ART. 4714B Parte esterna / External pieces / Parties externes / Up-Teil / Parte externa

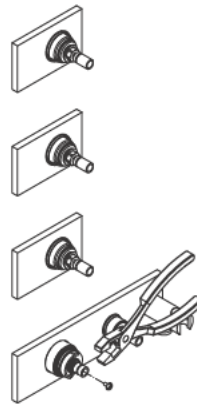

- Durante il montaggio e la manutenzione si consiglia di non ruotare il perno della cartuccia. Se necessita ristabilire la posizione di 38° C effettuare le procedure di pag. 25-26.
- During assembly and maintenance, it is advisable not to turn the cartridge pivot. If it is necessary to reposition to 38 °C, follow the procedure on page 25-26.
- Pendant le montage et l'entretien, il est conseillé de ne pas tourner le pivot de la cartouche. Si nécessaire, rétablir la position de 38°C. Effectuer les procédures indiquées à la p. 25-26.
- Es wird geraten, den Kartuschenstift während des Einbaus und der Instandhaltung nicht zu drehen. Sollte es nötig sein, auf 38 °C wieder zu positionieren, siehe die Prozedur auf Seite 25-26.
- Durante el montaje y mantenimiento se aconseja no girar el perno del cartucho. Si necesita restablecer la posición de 38°C llevar a cabo el procedimiento de la pág. 25-26.



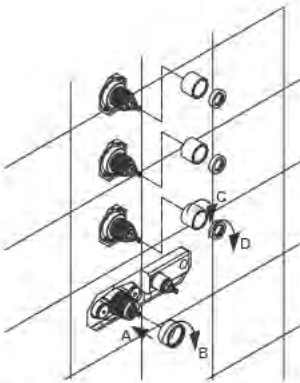

1.

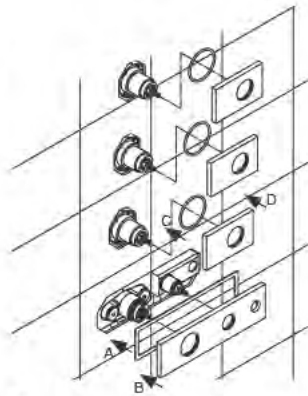

2.

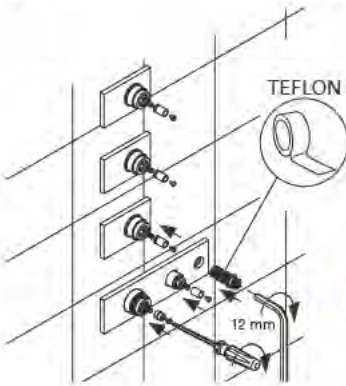

3.



- Quando si avvita l'adattatore cartuccia fare attenzione a non far ruotare l'asta della cartuccia (vedi pag. 16).
- When screwing on the cartridge adapter take care not to rotate the rod of the cartridge (see page 16).
- Veiller, en vissant l'adaptateur de la cartouche, à ne pas faire tourner la tige de la cartouche (voir p. 16).
- Beim Anschrauben des Kartuschenadapters sollte der Kartuschenstab nicht rotiert werden (siehe Seite 16).
- Cuando se atornilla el adaptador del cartucho tener la precaución de no girar el asta del cartucho (ver pag. 16).

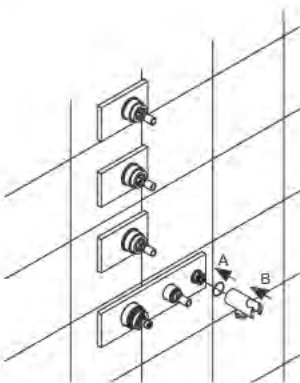

4.

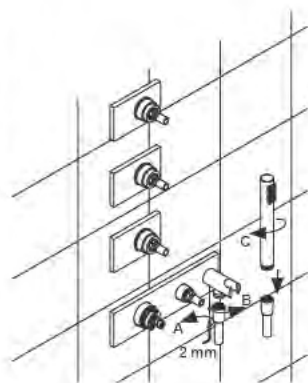

5.

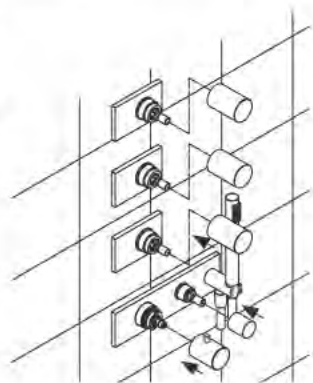

6.

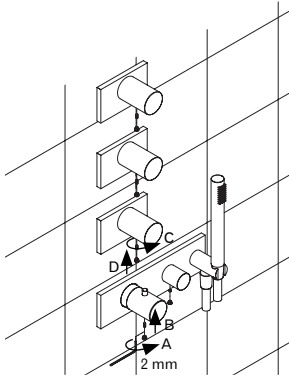

7.

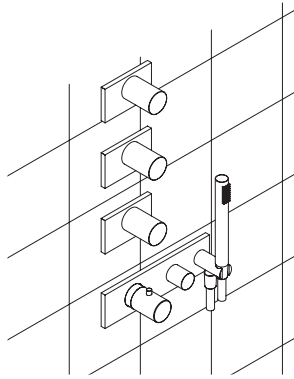

8.

Regolazioni / Adjustments / Ajustements / Anpassungen / Ajustes

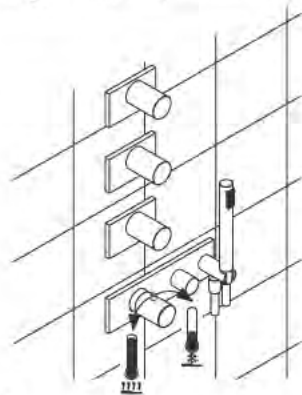

1.

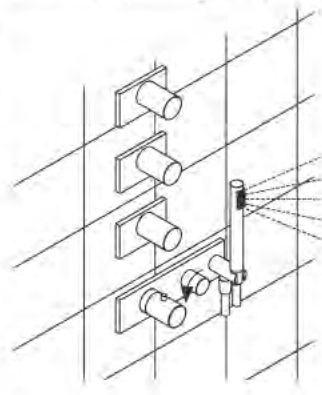

2.

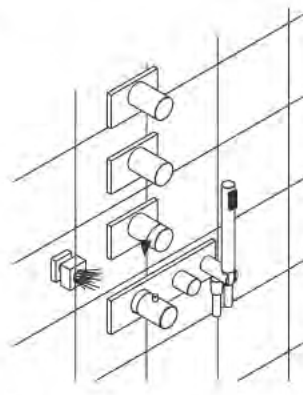

3.

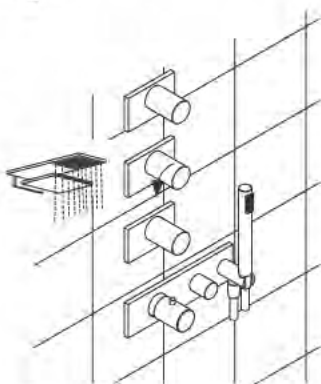

4.

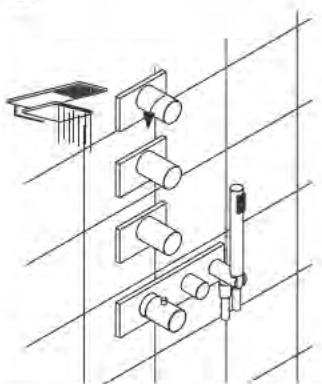

5.

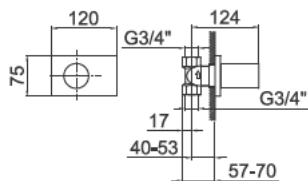

ART. 4790B Parte esterna / External pieces / Parties externes / Up-Teil / Parte externa

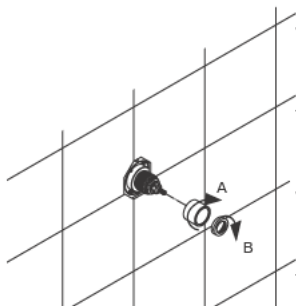

1.

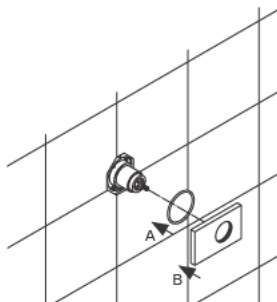

2.

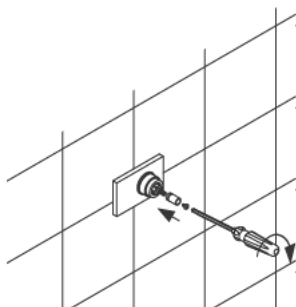

3.



- Quando si avvita l'adattatore cartuccia fare attenzione a non far ruotare l'asta della cartuccia (vedi pag. 4).
- When screwing on the cartridge adapter take care not to rotate the rod of the cartridge (see page 4).
- Veiller, en vissant l'adaptateur de la cartouche, à ne pas faire tourner la tige de la cartouche (voir p. 4).
- Beim Anschrauben des Kartuschenadapters sollte der Kartuschenstab nicht rotiert werden (siehe Seite 4).
- Cuando se atornilla el adaptador del cartucho tener la precaución de no girar el asta del cartucho (ver pag.4).

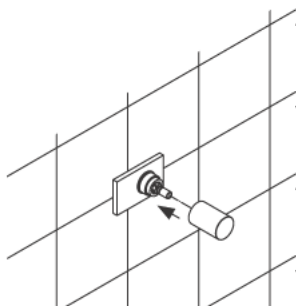

4.

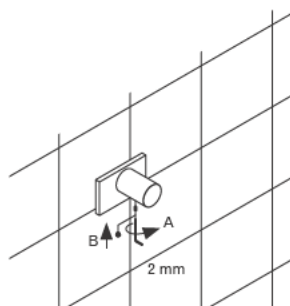

5.

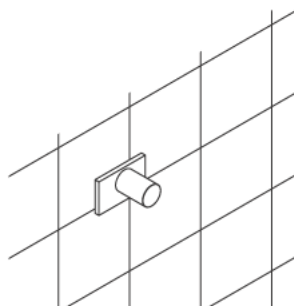

6.

Regolazioni / Adjustments / Ajustements / Anpassungen / Ajustes

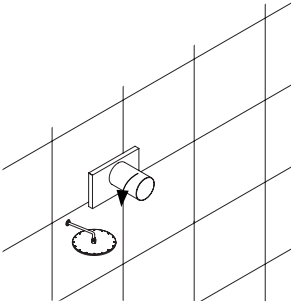

1.

**Sostituzione cartuccia / Cartridge replacement / Remplacement de la cartouche /
Auswechseln der Kartusche / Sustitucion del cartucho**
Per art. 4711B-4712B-4713B-4714B

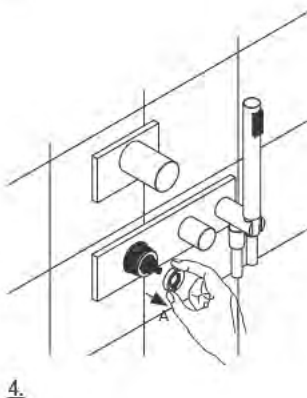
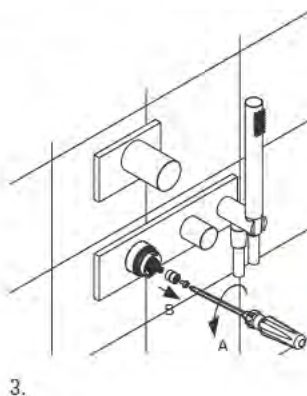
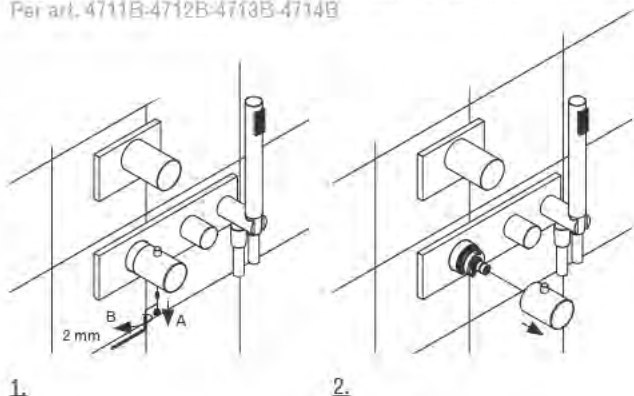

- Quando si svita la vite A delle figure 3 fare attenzione a non far ruotare l'asta della cartuccia (vedi pag. 4)
- When unscrewing the screw A in Ill. 3 take care not to rotate the rod of the cartridge (see page 4).
- Veiller, en dévissant la vis A des figures 3, à ne pas faire tourner la tige de la cartouche (voir p. 4)
- Beim Lockern der Schraube A in Abb. 3 sollte der Kartuschenstab nicht rotiert werden (siehe Seite 4).
- Cuando se desatornilla el tornillo A de las figuras 3, tener cuidado de no girar el asta del cartucho (ver pag. 4)

- Togliere l'anello bianco in plastica (A)
- Remove the white plastic ring (A)
- Ôter la bague blanche en plastique (A)
- Den weißen Plastikring entfernen (A)
- Remover el anillo de plástico blanco (A)

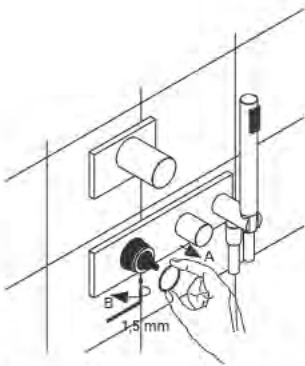

5.

- Togliere l'anello o'ring (A) e svitare con la chiave da 1,5 mm. il grano, ed estrarre la ghiera porta o'ring (A fig. 6).
- Remove the O ring (A) and using a spanner of 1.5 mm unscrew the dowel and remove the ring nut of the O ring (A III. 6).
- Ôter le joint torique (A) et dévisser le goujon avec une clé de 1,5 mm puis extraire la bague de support du joint torique (A fig. 6).
- Den O-Ring entfernen (A) und mit einem 1,5 mm Schlüssel den Dübel lockern und die Ringmutter von dem O-Ring entfernen (A Abb. 6).
- Remove el anillo o'ring (A) y desatornillar con la llave de 1,5 mm el prisionero, luego remover el buje porta o'ring (A fig. 6).

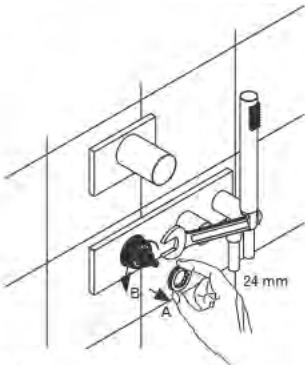

6.

- Con la chiave da 24 mm. svitare la cartuccia e poi toglierla.
- Using a spanner of 24 mm unscrew the cartridge and remove it.
- Dévisser la cartouche avec une clé de 24 mm puis la retirer.
- Mit einem 24 mm Schlüssel die Kartusche lockern und entfernen.
- Con la llave de 24 mm desatornillar el cartucho, luego sacar la llave de su posición.

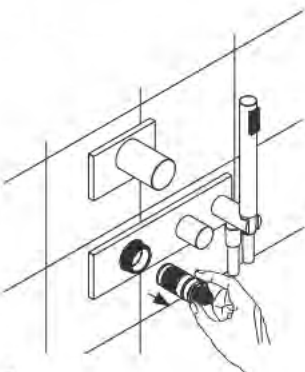

7.

Se la cartuccia non è da sostituire lavarla con acqua corrente e lasciarla immersa per una notte in aceto o in una soluzione decalcificante. Pulire l'interno del corpo miscelatore con un panno umido; lubrificare le guarnizioni intorno alla cartuccia e rimontarla nella sua sede seguendo il procedimento inverso (fig. 7-6-5 a pag. 24). Aprire le entrate delle acque e lasciare erogare il miscelatore per almeno un minuto fino ad ottenere una temperatura stabile. Girare dolcemente l'astina di regolazione di temperatura fino ad ottenere una temperatura di 38°C (100 F) sul vostro termometro. Ottenuta questa temperatura, posizionare l'anello bianco di plastica (A) sulla broccia della cartuccia, tenendo il segno rosso a ore 12 rispetto al corpo del miscelatore (fig. 4 pag. 23). Rimontare la maniglia di regolazione temperatura seguendo il procedimento inverso (fig. 2-1 a pag. 23) con il riferimento 38°C (100 F) della maniglia in corrispondenza del riferimento sul corpo miscelatore. Provare il buon funzionamento del rubinetto.

Se la cartuccia è da sostituire non è necessario eseguire la taratura sopra descritta perchè il ricambio viene fornito da Fantini S.p.A. già tarato sui 38°C (100 F). Rimontare seguendo il procedimento inverso 7-6-5-4-3-2-1 a pag. 24-23.

If the cartridge shall not be replaced, wash it with water and leave it dipped in vinegar or decalcifying solution over one night. Clean the mixer body inside with a damp cloth; lubricate the seals around the cartridge and put them back to their place by following the reverse procedure (fig. 7-6-5 page 24). Open the water inlet and leave the mixer deliver water for at least one minute, until the temperature is stable. Gently turn the temperature adjusting rod until achievement of 38° C (100 F) on your thermometer. Once achieved this temperature, place the white plastic ring (A) on the cartridge broach, keeping the red mark at h. 12 compared to the mixer body (Fig. 4 page 23). Reassemble the temperature adjusting knob following the reverse procedure (fig. 2-1 page 23) with the knob reference 38° C (100 F) on the mixer body. Try the smooth operation of the tap.

If the cartridge shall be replaced, it is not necessary to carry out the calibration described above, because the spare part supplied by Fantini SpA is already calibrated at 38° C (100 F). Reassemble following the reverse procedure 7-6-5-4-3-2-1 on page 24-23.

Si la cartouche ne doit pas être remplacée, lavez-la avec de l'eau et laissez-la tremper dans du vinaigre ou une solution décalcifiante pendant une nuit. Nettoyez l'intérieur du corps du mélangeur avec un chiffon humide; lubrifiez les joints autour de la cartouche et remettez-les à leur place en suivant la procédure inversée (fig. 7-6-5 page 24). Ouvrez les entrées de l'eau et laissez entrer l'eau pendant au moins une minute, jusqu'à ce que la température est stable. Tournez douce-ment la tige de réglage de la température jusqu'à atteindre 38° C (100 F) sur votre thermomètre. Une fois atteinte cette température, mettez la bague en plastique blanche (A) sur la broche de la cartouche, en maintenant le repère rouge à h. 12 par rapport au corps du mélangeur (Fig. 4 page 23). Remontez la poignée de réglage de la température en suivant la procédure inversée (fig. 2-1 page 23) avec le repère de la poignée de 38° C (100 F) sur le corps du mélangeur. Essayez le bon fonctionnement du robinet.

Si la cartouche doit être remplacée, il n'est pas nécessaire de procéder au calibrage ci-dessus, parce que la pièce de rechange fournie par Fantini SpA est déjà calibrée à 38° C (100 F). Remontez en suivant la procédure inverse 7-6-5-4-3-2-1 à la page 24-23.

Wenn die Kartusche nicht ersetzt werden muss, sie unter laufendem Wasser waschen und übernacht entweder in Essig oder in einer Entkalkungslösung einweichen. Die Innenseite des Mixerkörpers mit einem feuchten Lappen säubern; die Scheiben um die Kartusche einschmieren und die Kartusche wieder auf ihren Platz setzen, indem die Prozedur umgekehrt wird (Abb. 7-6-5 auf Seite 24). Die Wassereingänge öffnen und somit den Mixer mindestens eine Minute lang versorgen, bis eine gleich bleibende Temperatur erreicht wird. Vorsichtig den Temperaturregulationsstab drehen, um eine Temperatur von 38 C (100 F) auf dem Thermometer zu erreichen. Wenn diese Temperatur erreicht wird, den weißen Plastikring (A) auf den Kartuschenanschluss setzen, indem das rote Zeichen auf „12 Uhr“ im Verhältnis zum Mixer gehalten wird (Abb. 4 Seite 23). Den Temperaturregulationsgriff wieder anbringen, indem die Prozedur umgekehrt wird (Abb. 2-1 auf Seiten 23) so dass die Referenztemperatur von 38 C (100 F) des Griffs mit der Referenz auf dem Mixerkörper übereinstimmt. Das Funktionieren des Hahns überprüfen.

Wenn die Kartusche ersetzt werden muss, ist es nicht notwendig, die Eichung wie oben beschrieben durchzuführen, weil das Auswechseln von Fantini S.p.A. schon auf 38 C (100 F) geeicht ausgeführt wird. Wieder anbringen, indem die Prozedur umgekehrt wird 7-6-5-4-3-2-1 auf Seiten 24-23.

Si el cartucho no debe ser sustituido, lavarlos con agua y dejarlo sumergido en vinagre o solución de descalcificación una noche. Limpiar el cuerpo dentro del mezclador con un paño húmedo; lubricar los sellos alrededor del cartucho y ponerlos de nuevo a su lugar con el procedimiento invertido (fig. 7-6-5 página 24). Abrir las entradas de agua y dejar fluir el agua al menos un minuto, hasta que la temperatura es estable. Suavemente girar la barra de ajuste de la temperatura hasta alcanzar los 38 ° C (100 F) en su termómetro. Una vez alcanzada esta temperatura, poner el anillo de plástico blanco (A) en la brocha del cartucho, manteniendo la marca roja en h. 12 con respecto al cuerpo del mezclador (Fig. 4 página 23). Montar la palanca para ajustar la temperatura con el procedimiento invertido (fig. 2-1 página 23) con la referencia de 38° C (100 F) sobre el cuerpo del mezclador. Probar el buen funcionamiento del grifo.

Si el cartucho debe ser sustituido, no es necesario llevar a cabo la calibración descrita anteriormente, porque la pieza de recambio suministrada por Fantini SpA ya está calibrada a 38 ° C (100 F). Montar con el procedimiento inverso 7-6-5-4-3-2-1 en la página 24-23.

Sostituzione vitone / Bolt Replacement / Remplacement de la tôle
 Oberteilsersetzung / Sustitución tassa de extrusión
 Per art. 4711B-4712B-4713B-4714B-4790B

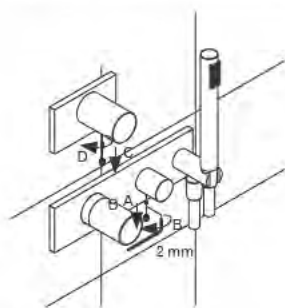

1.

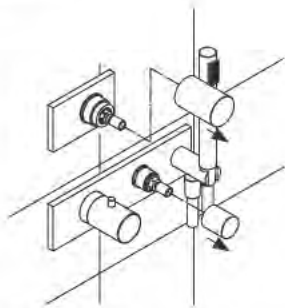

2.

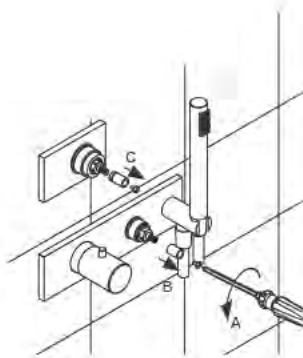

3.

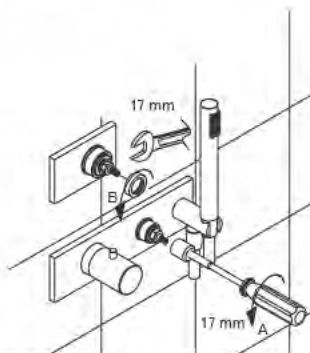

4.

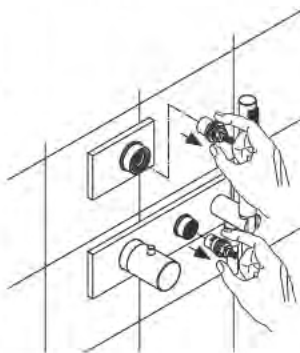

5.

Rimontare seguendo il procedimento inverso (5-4-3-2-1).

Replace following the instructions in reverse order (5-4-3-2-1).

Re-installer au contraire du procédé (5-4-3-2-1).

Die umgekehrte Vorgehensweise folgen um die Teil wieder zu installieren (5-4-3-2-1).

Colocar según el procedimiento inverso (5-4-3-2-1).

Pulizia valvola di non ritorno / Cleaning backflow prevention valve / Nettoyage clapet anti-rétour
 Reinigung Rückschlagventil / Limpieza válvula anti-retorno

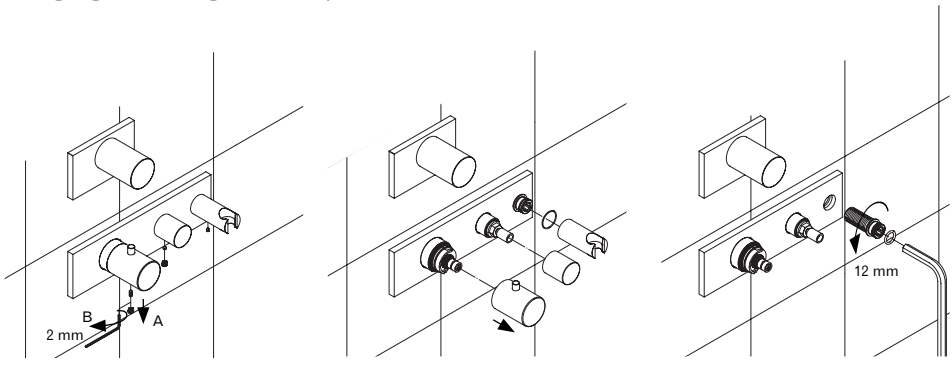

1.

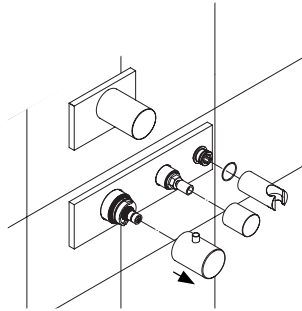

2.

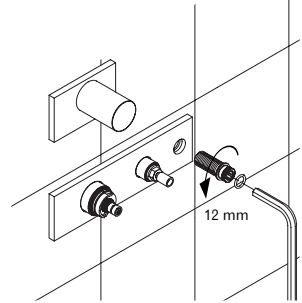

3.

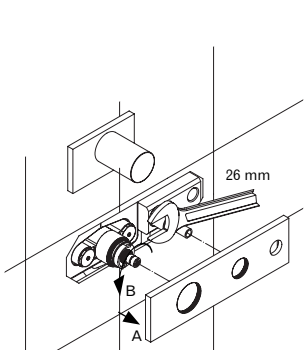

4.

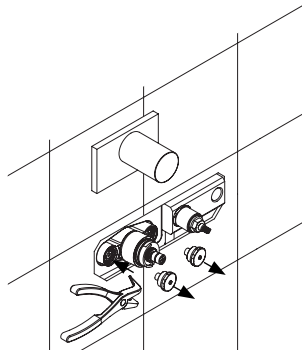

5.

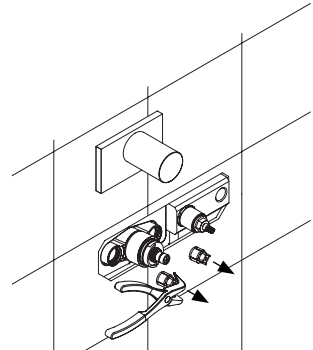

6.

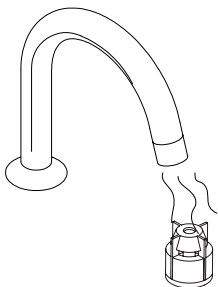

7.

Rimontare seguendo il procedimento inverso (6-5-4-3-2-1).
 Replace following the instructions in reverse order (6-5-4-3-2-1).
 Re-installer au contraire du procédé (6-5-4-3-2-1).
 Die umgekehrte Vorgehensweise folgen um die Teil wieder zu installieren (6-5-4-3-2-1).
 Colocar según el procedimiento inverso (6-5-4-3-2-1).

Montaggio prolunghe da 20 mm. / Mounting 20 mm extension / Montage rallonges 20 mm
 Montage 20 mm Verlängerung / Montaje de 20 mm de prolonogaciones

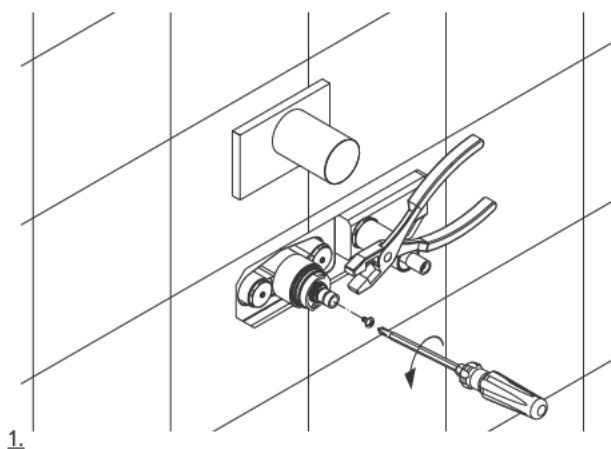

- Durante il montaggio e la manutenzione si consiglia di non ruotare il perno della cartuccia. Se necessita ristabilire la posizione di 38° C effettuare le procedure di pag. 25-26.
- During assembly and maintenance, it is advisable not to turn the cartridge pivot. If it is necessary to reposition to 38 °C, follow the procedure on page 25-26.
- Pendant le montage et l'entretien, il est conseillé de ne pas tourner le pivot de la cartouche. Si nécessaire, rétablir la position de 38°C. Effectuer les procédures indiquées à la p. 25-26.
- Es wird geraten, den Kartuschenstift während des Einbaus und der Instandhaltung nicht zu drehen. Sollte es nötig sein, auf 38 °C wieder zu positionieren, siehe die Prozedur auf Seite 25-26.
- Durante el montaje y mantenimiento se aconseja no girar el perno del cartucho. Si necesita restablecer la posición de 38°C llevar a cabo el procedimiento de la pág. 25-26.



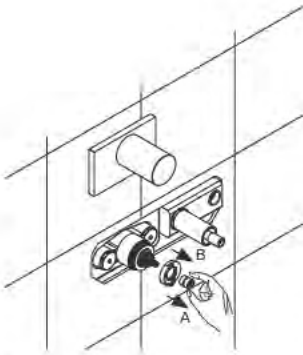

2.

- Togliere l'anello bianco in plastica (B)
- Remove the white plastic ring (B)
- Ôter la bague blanche en plastique (B)
- Den weißen Plastikring entfernen (B)
- Remover el anillo de plástico blanco (B)

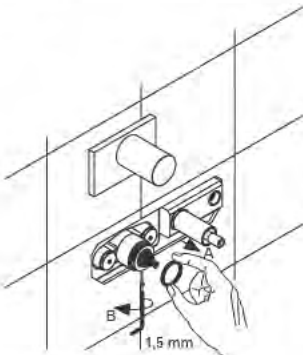

3.

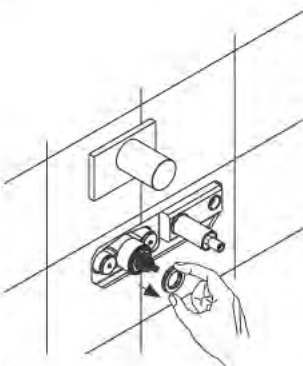

4.

- Togliere l'anello o'ring (A) e svitare con la chiave da 1.5 mm, il grano (fig. 3), ed estrarre la ghiera porta o'ring (fig. 4).
- Remove the O ring (A) and using a spanner of 1.5 mm (Ill. 3) unscrew the dowel and remove the ring nut of the O ring (Ill. 4).
- Ôter le joint torique (A) et dévisser le goujon avec une clé de 1.5 mm (fig. 3) puis extraire la bague de support du joint torique (fig. 4).
- Den O-Ring entfernen (A) und mit einem 1,5 mm (Abb. 3) Schlüssel den Dübel lockern und die Ringmutter von dem O-Ring entfernen (Abb. 4).
- Remover el anillo o'ring (A) y desatornillar con la llave de 1,5 mm el prisionero (fig. 3), luego remover el buje porta o'ring (fig. 4).

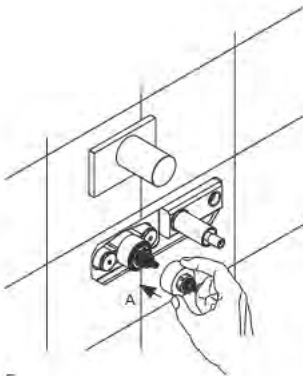

5.

- Inserire la bussola all'interno della prolunga (A) e montare la prolunga sulla cartuccia (fig. 5).
- Then insert the bush into the extension (A) and mount the extension on the cartridge (Ill. 5).
- Mettre la bague à l'intérieur de l'extension (A) et installer l'extension sur la cartouche (fig. 5).
- Dann die Hülse in die Verlängerung (A) inserieren und die Verlängerung an die Kartusche anbringen (Abb. 5).
- A continuación, introducir el anillo en la prolongación (A) e instalar la prolongación en el cartucho (fig. 5).

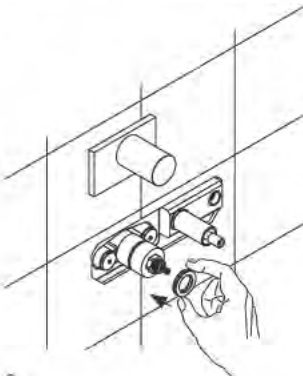

6.

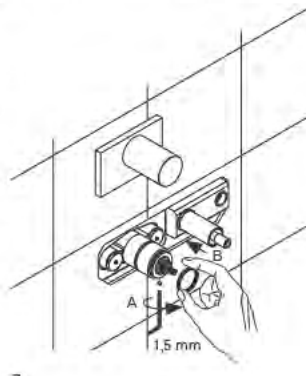

7.

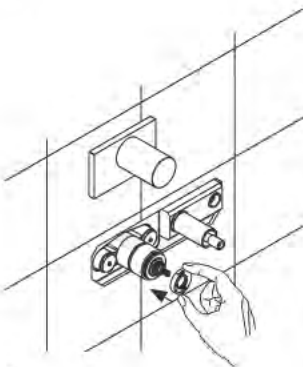

8.

- Posizionare l'anello bianco di plastica tenendo il segno rosso a ore 12 rispetto al corpo del miscelatore come mostrato in figura 8.
- Position the white plastic ring with the red marking at 12 o'clock in relation to the mixer body as shown in Ill. 8.
- Placer la bague blanche en plastique en situant la marque rouge à 12 heures d'intervalle par rapport au corps mélangeur comme cela est indiqué sur la figure H8.
- Den weißen Plastikring platzieren mit der roten Markierung in der 12 Uhr Position in Beziehung zum Mixerkörper, wie in Abb. 8.
- Posicionar el anillo blanco de plástico dejando la marca roja en la posición de las 12 hs respecto del cuerpo del mezclador como se muestra en la figura 8.

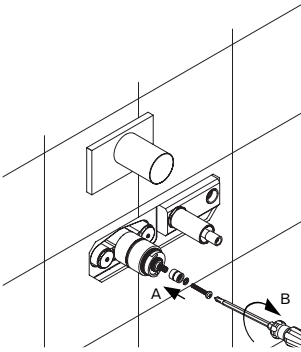

9.

- Quando si avvita l'adattatore cartuccia fare attenzione a non ruotare l'asta della cartuccia come mostrato nella figura 1. (Vedi pagina 29).
- When screwing on the cartridge adapter, take care not to rotate the rod of the cartridge as shown in Ill. 1 (see page 29).
- Veiller, en vissant l'adaptateur de la cartouche, à ne pas faire tourner la tige de la cartouche comme cela est indiqué dans le figure 1. (Voir page 29).
- Beim Lockern des Kartuschenadapters sollte der Kartuschenstab nicht rotiert werden, wie in Abb. 1 (siehe Seite 29).
- Cuando se atornilla el adaptador del cartucho tener cuidado de no hacer girar el asta del cartucho como se muestra en las figuras 1 (ver página 29).

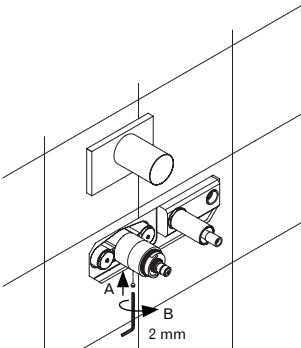

10.

Montaggio prolunghe da 20 mm. rubinetto doccia / Mounting 20 mm extension built-in handshower / Montage rallonges 20 mm robinet de douche / Montage 20 mm Verlängerung Brausebaltene / Montaje de 20 mm de prolongaciones

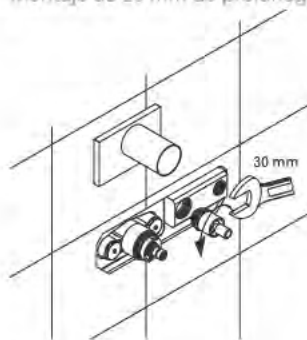

1.

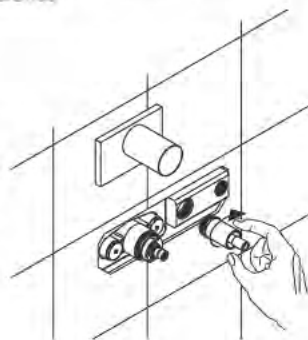

2.

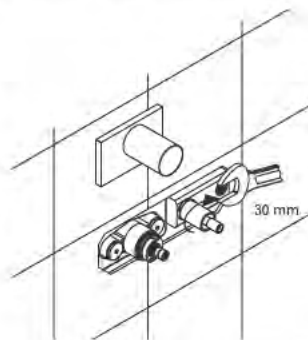

3.

Montaggio prolunghe da 35 mm. / Mounting 35 mm extension / Montage rallonges 35 mm
Montage 35 mm Verlängerung / Montaje de 35 mm de prolonogaciones

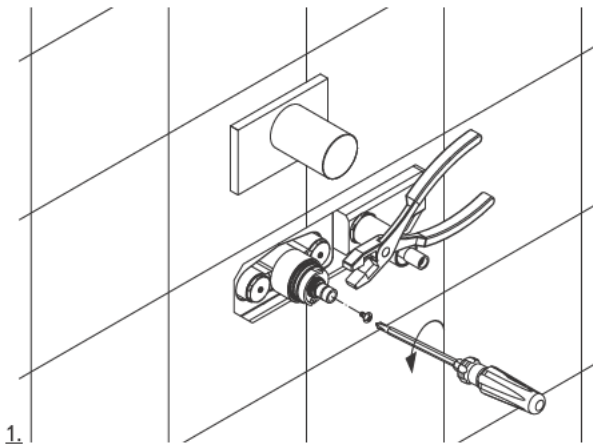

- Durante il montaggio e la manutenzione si consiglia di non ruotare il perno della cartuccia. Se necessita ristabilire la posizione di 38° C effettuare le procedure di pag. 25-26.
- During assembly and maintenance, it is advisable not to turn the cartridge pivot. If it is necessary to reposition to 38 °C, follow the procedure on page 25-26.
- Pendant le montage et l'entretien, il est conseillé de ne pas tourner le pivot de la cartouche. Si nécessaire, rétablir la position de 38°C. Effectuer les procédures indiquées à la p. 25-26.
- Es wird geraten, den Kartuschenstift während des Einbaus und der Instandhaltung nicht zu drehen. Sollte es nötig sein, auf 38 °C wieder zu positionieren, siehe die Prozedur auf Seite 25-26.
- Durante el montaje y mantenimiento se aconseja no girar el perno del cartucho. Si necesita restablecer la posición de 38°C llevar a cabo el procedimiento de la pág. 25-26.



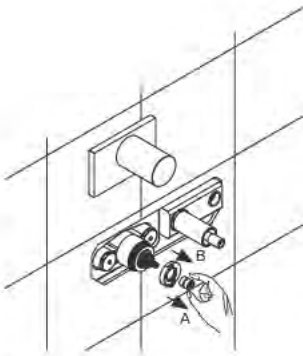

2.

- Togliere l'anello bianco in plastica (B)
- Remove the white plastic ring (B)
- Ôter la bague blanche en plastique (B)
- Den weißen Plastikring entfernen (B)
- Remover el anillo de plástico blanco (B)

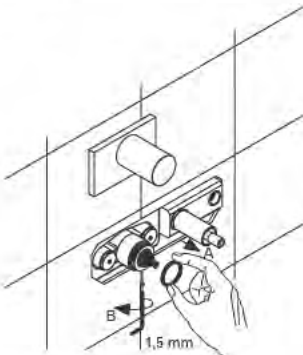

3.

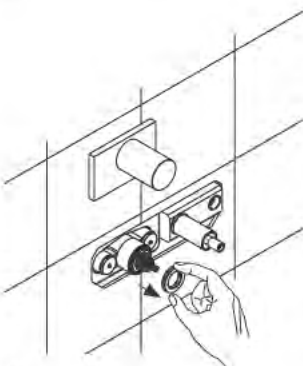

4.

- Togliere l'anello o'ring (A) e svitare con la chiave da 1.5 mm, il grano (fig. 3), ed estrarre la ghiera porta o'ring (fig. 4).
- Remove the O ring (A) and using a spanner of 1.5 mm (Ill. 3) unscrew the dowel and remove the ring nut of the O ring (Ill. 4).
- Ôter le joint torique (A) et dévisser le goujon avec une clé de 1.5 mm (fig. 3) puis extraire la bague de support du joint torique (fig. 4).
- Den O-Ring entfernen (A) und mit einem 1,5 mm (Abb. 3) Schlüssel den Dübel lockern und die Ringmutter von dem O-Ring entfernen (Abb. 4).
- Remover el anillo o'ring (A) y desatornillar con la llave de 1,5 mm el prisionero (fig. 3), luego remover el buje porta o'ring (fig. 4).



5.

- Inserire l'anello di ottone (A) nella bussola di plastica (B) (fig. 5). Successivamente inserire la bussola all'interno della prolunga (C) e montare la prolunga sulla cartuccia.
- Insert the copper ring (A) into the plastic bush (B) (Ill. 5). Then insert the bush into the extension (C) and mount the extension on the cartridge.
- Insérer la bague en laiton (A) dans la bague en plastique (B) (fig. 5). Ensuite, mettre la bague à l'intérieur de l'extension (C) et installer l'extension sur la cartouche.
- Den Kupferring (A) in die Plastikhülse inserieren (B) (Abb. 5). Dann die Hülse in die Verlängerung (C) inserieren und die Verlängerung an die Kartusche anbringen.
- Insertar el anillo de bronce (A) en el anillo de plástico (B) (fig. 5). A continuación, introducir el anillo en la prolongación (C) e instalar la prolongación en el cartucho.

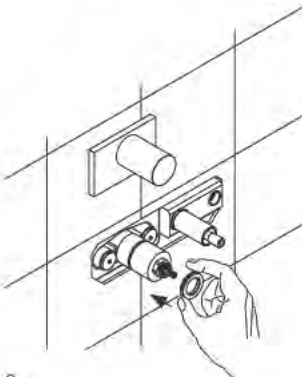

6.

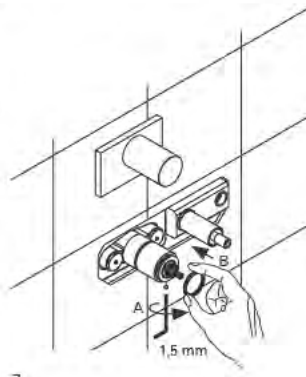

7.

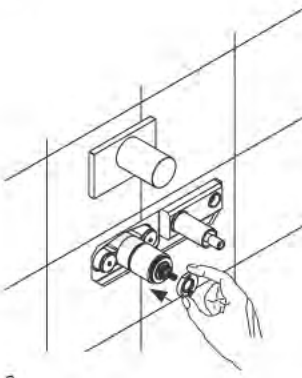

8.

- Posizionare l'anello bianco di plastica tenendo il segno rosso a ore 12 rispetto al corpo del miscelatore come mostrato in figura 8.
- Position the white plastic ring with the red marking at 12 o'clock in relation to the mixer body as shown in Ill. 8.
- Placer la bague blanche en plastique en situant la marque rouge à 12 heures d'intervalle par rapport au corps mélangeur comme cela est indiqué sur la figure H8.
- Den weißen Plastikring platzieren mit der roten Markierung in der 12 Uhr Position in Beziehung zum Mixerkörper, wie in Abb. 8.
- Posicionar el anillo blanco de plástico dejando la marca roja en la posición de las 12 hs respecto del cuerpo del mezclador como se muestra en la figura 8.

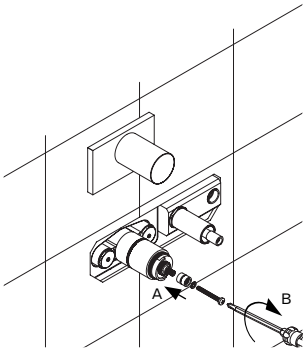

9.

- Quando si avvita l'adattatore cartuccia fare attenzione a non ruotare l'asta della cartuccia come mostrato nella figura 1. (Vedi pagina 34).
- When screwing on the cartridge adapter, take care not to rotate the rod of the cartridge as shown in Ill. 1 (see page 34).
- Veiller, en vissant l'adaptateur de la cartouche, à ne pas faire tourner la tige de la cartouche comme cela est indiqué dans le figure 1. (Voir page 34).
- Beim Lockern des Kartuschenadapters sollte der Kartuschenstab nicht rotiert werden, wie in Abb. 1 (siehe Seite 34).
- Cuando se atornilla el adaptador del cartucho tener cuidado de no hacer girar el asta del cartucho como se muestra en las figuras 1 (ver página 34)

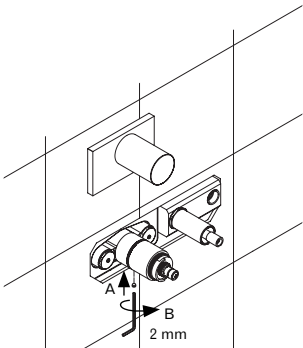

10.

Montaggio prolunghe da 35 mm. rubinetto doccia / Mounting 85 mm extension built-in handshower / Montage rallonges 35 mm robinet de douche / Montage 35 mm Verlängerung Brausebatterie / Montaje de 35 mm de prolongaciones

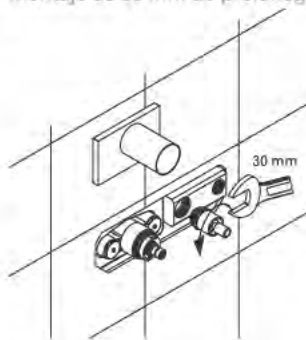

1.

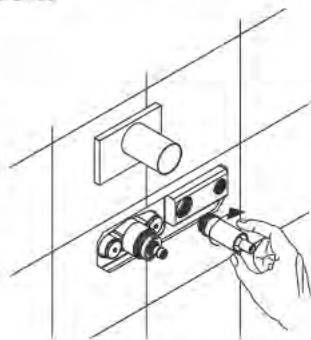

2.

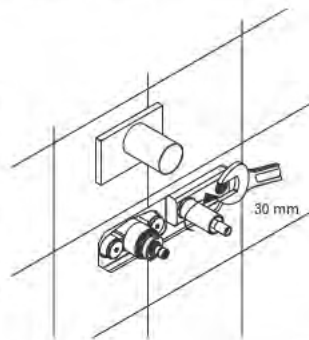

3.

**Montaggio prolunghe rubinetto d'arresto / Mounting extension stopcock /
Montage rallonges taping les extensions arrestó / Montage Verlängerung Hahnverlängerungen /
Montaje de prolongaciones arrestó**

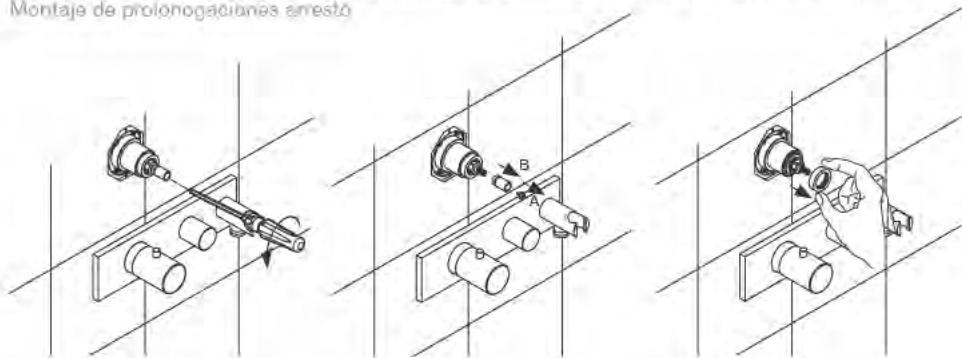

1.

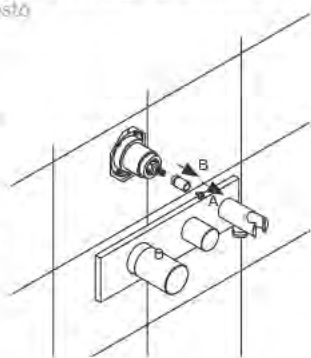

2.

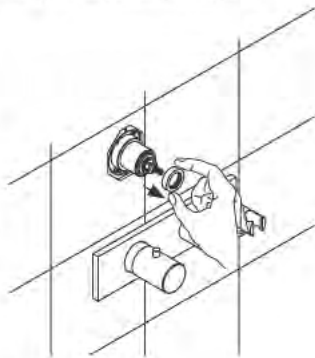

3.

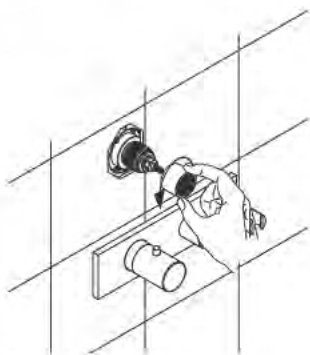

4.

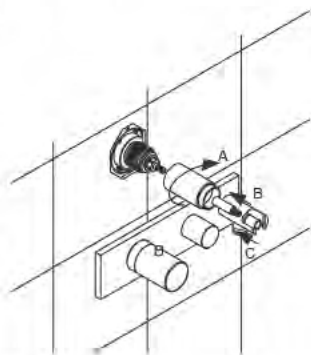

5.

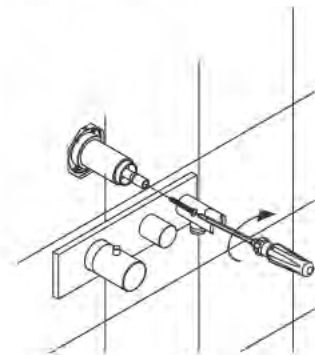

6.

Dati tecnici

Pressione minima, _____, 1 BAR
 Pressione massima, _____, 10 BAR
 Pressione di esercizio consigliata, _____, 2-5 BAR
 Temperatura massima, _____, 80°
 Temperatura massima consigliata, _____, Min. 55 Max 65°C
 Differenza massima di pressione in arrivo (calda - fredda), _____, 1.5 BAR

Applicazioni

Questi miscelatori possono essere utilizzati con accumulatori di acqua calda a pressione o con scaldabagni istantanei.

Avvertenze

Prima di installare é necessario spurgare in modo accurato le tubazioni di alimentazione.

ITALY.

Technical data

Minimum pressure, _____, 1 BAR
 Maximum pressure, _____, 10 BAR
 Recommended working pressure, _____, 2-5 BAR
 Maximum water temperature, _____, 80°
 Maximum water temperature recommended, _____, Min. 55 Max 65°C
 Maximum in-let pressure difference (hot - cold), _____, 1.5 BAR

Operating instructions

These mixers can be used with cumulos boilers or instantaneous water heaters.

Warning

The supplying pipes must be carefully cleaned before installation.

ENGLAND.

Caractéristiques techniques

Pression minimum, _____, 1 BAR
 Pression maximum, _____, 10 BAR
 Pression optimale de service, _____, 2-5 BAR
 Température maximum, _____, 80°
 Température maximum optimale, _____, Min. 55 Max 65°C
 Différence maximum de Pression d'arrivée (chaud - froid), _____, 1.5 BAR

Mode d'emploi

Ces mitigeurs peuvent être utilisés avec accumulateurs d'eau chaude à pression ou avec des chauffe-eau instantanés.

Note

Il est indispensable que les raccords d'alimentation soient purgés avant la mise en place de l'appareil.

FRANCE.

Technische Daten

Minimum druck, _____, 1 BAR
 Höchste druck, _____, 10 BAR
 Empfehlener druck, _____, 2-5 BAR
 Höchste wasser Temperatur, _____, 80°
 Empfehlener höchste Wassertemperatur, _____, Min. 55 Max 65°C
 Höchste einkommende Drucksunterschied (Warm - kalt), _____, 1.5 BAR

Betriebsanweisungen

Diese Mischer sind sowie für Heisswasserspeicher als auch für Durchlaufhitzer geeignet.

Note

Die Verbindungsröhre vor der Montage sorgfältig putzen.

GERMANY.

Datos Técnicos

Pression mínima, _____, 1 BAR
 Pression máxima, _____, 10 BAR
 Pression de trabajo aconsejada, _____, 2-5 BAR
 Temperatura máxima, _____, 80°
 Temperatura máxima aconsejada, _____, Min. 55 Max 65°C
 Diferencial máxima de presión de entrada (caliente - fria), _____, 1.5 BAR

Aplicaciones

Estos monomandos pueden ser utilizados con acumuladores de agua caliente a presión.

Advertencias

Antes de conectar el monomando es necesario purgar correctamente la instalación hidráulica de alimentación de cualquier impureza que pueda tener.

SPAIN.

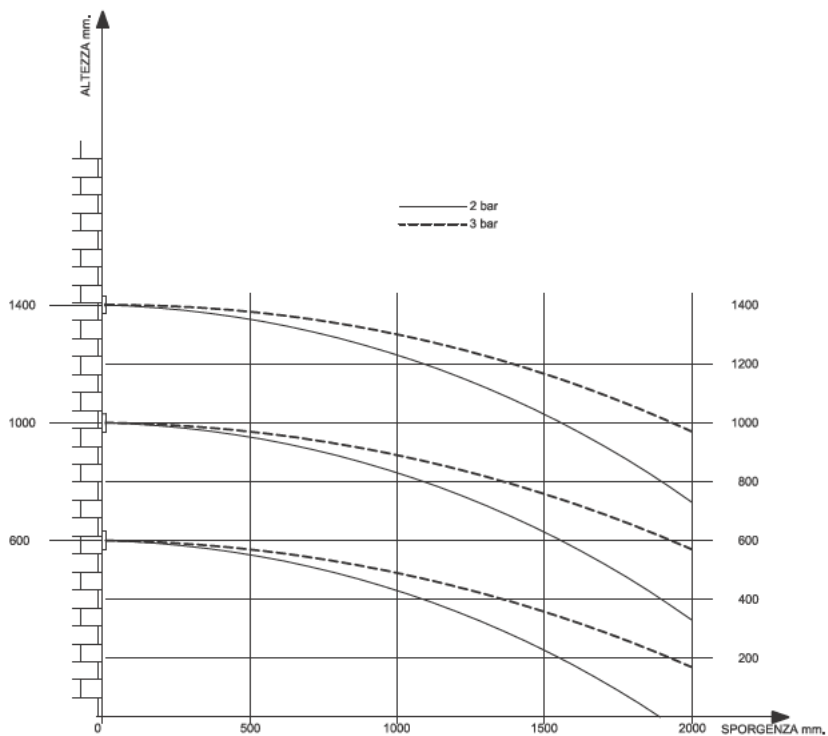

Portata miscelatore con uscite non collegate:
 Mixer feed with exit not connected:
 Débit mitigeur avec sorties non raccordées:
 Mixerzufuhr mit ausgang nicht angeschlossen:
 Capacidad mezclador con salidas no conectadas:

PRESSIONE bar	PORTATA l/min
0,5	15,5
1	24
2	33,5
3	42
4	48
5	52

Portate agli utilizzi
 Feed to the cycle
 Débit aux unités alimentées
 Zufuhr zum zyklus
 Capacidad para los usos

Soffione cascata Shower head waterfall Pomme de douche à cascade Schwallbrause Rociador en cascada	
Pressione Pressure Pression Wasserdruck Presión	Portata Flow rate Débit d'eau Durchfluss Caudal
0,5 bar	5,5 l/min
1 bar	8,5 l/min
2 bar	12 l/min
3 bar	14 l/min
4 bar	15 l/min
5 bar	15,5 l/min

Doccetta Handshower Douchette Handbrause Teleducha	
Pressione Pressure Pression Wasserdruck Presión	Portata Flow rate Débit d'eau Durchfluss Caudal
0,5 bar	5,5 l/min
1 bar	9 l/min
2 bar	14 l/min
3 bar	17,5 l/min
4 bar	20,5 l/min
5 bar	22,5 l/min

N. 6 Getti laterali N. 6 Lateral body spray N. 6 Jet d'eau lateral Seiten körperbrausen(n°6) Jets laterales(n°6)	
Pressione Pressure Pression Wasserdruck Presión	Portata Flow rate Débit d'eau Durchfluss Caudal
0,5 bar	11,5 l/min
1 bar	18,0 l/min
2 bar	25,5 l/min
3 bar	30 l/min
4 bar	33 l/min
5 bar	33,5 l/min

Soffione pioggia Shower head rainfall Pomme de douche à pluie Kopfbrause Rociador de lluvia	
Pressione Pressure Pression Wasserdruck Presión	Portata Flow rate Débit d'eau Durchfluss Caudal
0,5 bar	5,5 l/min
1 bar	8,5 l/min
2 bar	12 l/min
3 bar	14 l/min
4 bar	15 l/min
5 bar	15,5 l/min

Cura del prodotto

La pulizia delle superfici va fatta utilizzando un sapone liquido diluito in acqua.

Non usare mai in nessun caso detersivi liquidi contenenti sostanze abrasive o a base di acido muriatico, spugne abrasive, aceto, ammoniaca, acetone, candeggina, acidi di uso domestico, disinfettanti vari.

ATTENZIONE! L'impiego di prodotti non consigliati può deteriorare irrimediabilmente le superfici, nel qual caso il produttore non risponderà del danno.

L'azienda si riserva in qualunque momento di apportare senza preavviso modifiche a prodotti e accessori.

I dati riprodotti in questo documento hanno carattere informativo e non sono vincolanti.

ITALY.**Advice on product care**

To clean the surface use a soap and water solution.

Never use for any reason cleaning solutions containing abrasive substances, chloric acids, ammonia, vinegar, bleach, domestic acids, disinfectants, or anytype of abrasive pad.

WARNING! Incorrect cleaning may permanently ruin the surface of the products and in such case the manufacturer may not be held liable for damage.

The Manufacturer reserves the right to modify product and accessories at any time without prior notice. Data, products and sketches included in this document are just for information and do not bind the producer.

ENGLAND.**Conseils pour l'entretien du produit**

La poussière en surface devra être faite en utilisant un savon liquide dilué dans l'eau.

Ne jamais utiliser en aucun cas des détergents liquides contenant des substances abrasives ou à base d'acide, nid'éponges abrasives, vinaigre, ammoniacque, acétone, eau de Javel, acides à usage domestique, désinfectants divers.

ATTENTION! L'empli de produits non conseillés peut détériorer irrémédiablement la surface des articles pour lesquels le fabricant ne sera pas responsable.

La société se réserve le droit de modifier ses produits et ses accessoires à tout moment et sans préavis. Informations, produits et croquis reproduits dans ce documents sont de nature informative et ne sont pas contractuels.

FRANCE.**Pflege hinweise unserer artikel**

Zur Reinigung empfehlen wir Wasser und flüssige Seife.

Verwenden Sie bitte nie flüssige Reinigungsmittel, die Schmirgel, Salzsäure, Essig, Ammoniak, Aceton, Bleichlange, Desinfektionsmittel u.s.w. enthalten.

WARNUNG! Der Gebrauch solcher Mittel kann unsere Artikel beschädigen und in diesem Fall gewährt Hersteller keine Garantie.

Der Hersteller behalt sich das Recht vor jederzeit Änderungen an seinen Produkten und Zubehörteilen ohne Vorbescheid vorzunehmen. Katalogangaben sowie Abbindungen, Maß- und Leistungsangaben sind unverbindlich.

GERMANY.**Consejos para el cuidado del producto**

La limpieza de las superficies se hace utilizando un jabón liquido diluido en agua.

No usar en ningún caso detergentes liquidos que contengan sustancias abrasivas ó a base de ácido clorhídrico, estropajossabrosivos, amoniaco, acetona, lejía, ácidos de uso doméstico, desinfectantes varios.

ATENCIÓN! El uso de productos desaconsejados puede danär irremediabilmente las superficies de los elementos, de lo cual el fabricante no se hará responsable en ningún caso.

La sociedad se reserva el derecho de modificar sus productos y accesorios en cualquier momento y sin previo aviso.

SPAIN.



**Australian Standard
Installation**

Products shall be installed in accordance with AS/NZS 3500 series of standards.
Installer shall ensure that the flow controlled aerator is tightened to prevent removal by hand.