



Art. 3606SF - 3606SWF

- Miscelatore lavabo alto con scarico e flessibili
- High single-ever washbasin mixer with drain with flexibles
- Mitigeur lavabo surélevé avec vidage avec flexibles souples
- Waschtisch hohe mischer mit ablaufgarnitur, mit flexschlauch, ohne griff
- Monomando lavabo alto con desagüe, con flexo, sin maneta



Art. 3607SF - 3607SWF

- Miscelatore lavabo alto con scarico e flessibili
- High single-ever washbasin mixer with drain with flexibles
- Mitigeur lavabo surélevé avec vidage avec flexibles souples
- Waschtisch hohe mischer mit ablaufgarnitur, mit flexschlauch, ohne griff
- Monomando lavabo alto con desagüe, con flexo, sin maneta

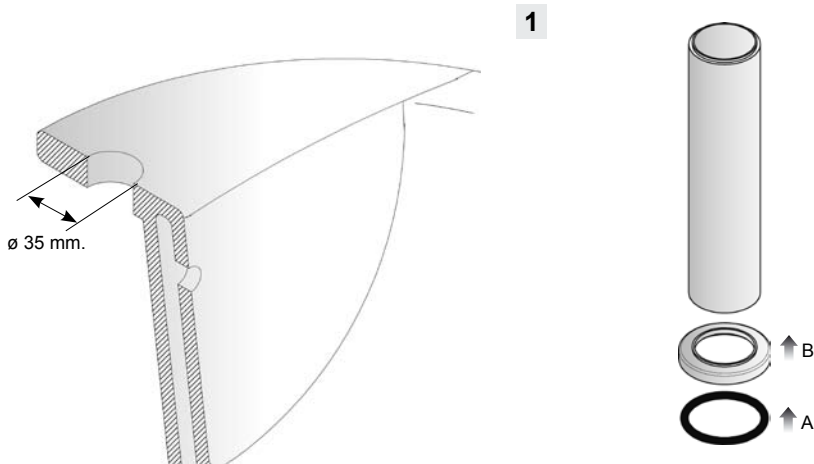

ATTENZIONE!

Prima di collegare i flessibili di alimentazione a seconda della maniglia acquistata, seguire le procedure di montaggio, come descritto nella figura 2 di pag. 7.

WARNING!

Before connecting the feed tubes, depending on the handle used, follow the assembly procedure as described in Fig. 2 on page 7.

ATTENTION!

Avant de relier les flexibles d'alimentation en fonction de la poignée achetée, suivre les procédures de montage, comme cela est décrit sur la figure 2 de la p. 7.

ACHTUNG!

Bevor die Zufuhrschläuche angeschlossen werden, abhängig vom gekauften Griff, die Anleitung wie in Zeichnung 2 auf Seite 7 folgen.

¡ATENCIÓN!

Antes de conectar los flexibles de alimentación, dependiendo de la manija comprada, seguir el proceso de montaje, como se describe en la figura 2 de pag. 7.

2

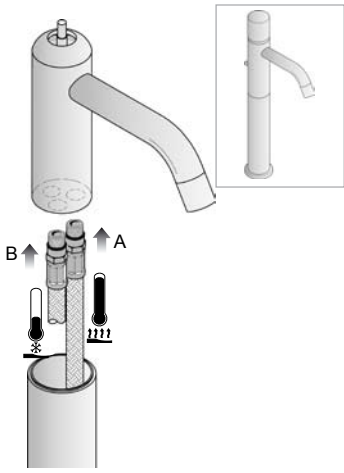

2

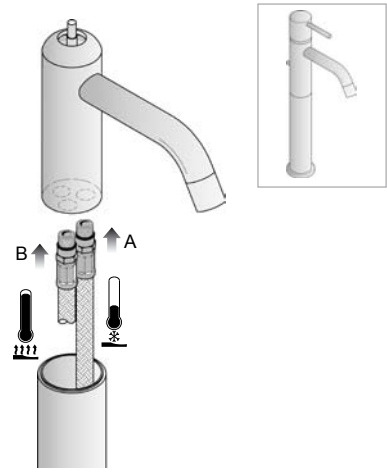

3

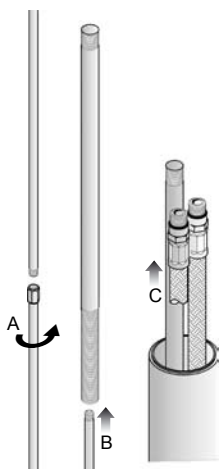

4

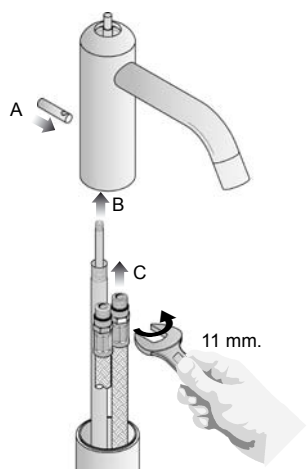

5

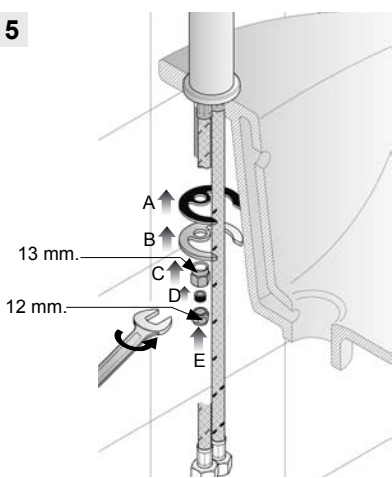

6

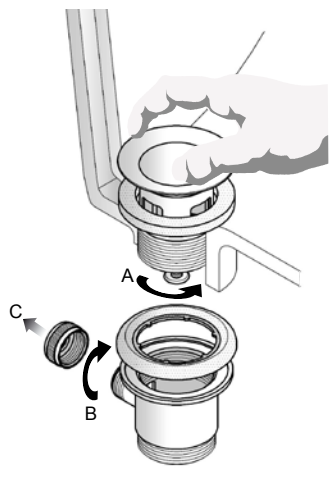

7

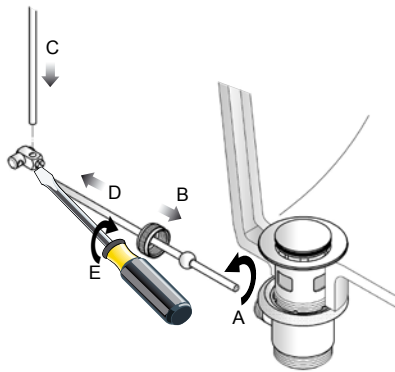

8

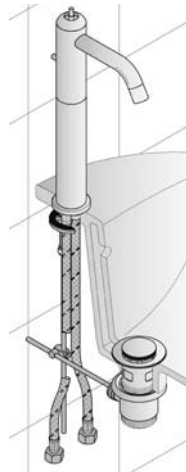



Art. 3648

- Maniglia
- Handle
- Manette
- Hebel
- Maneta

1

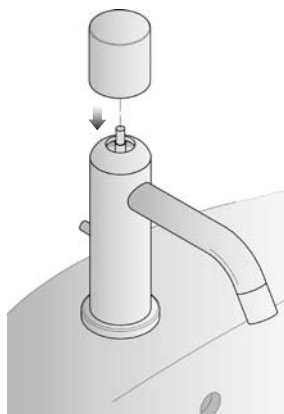

2

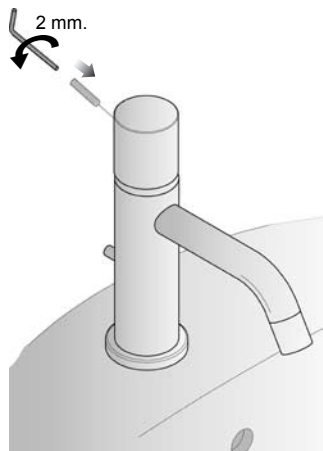

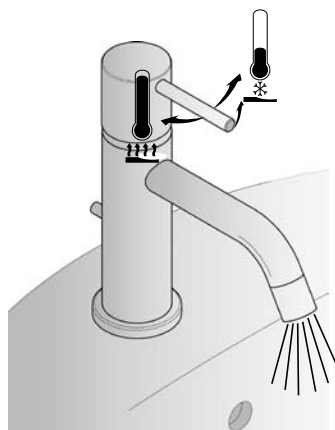
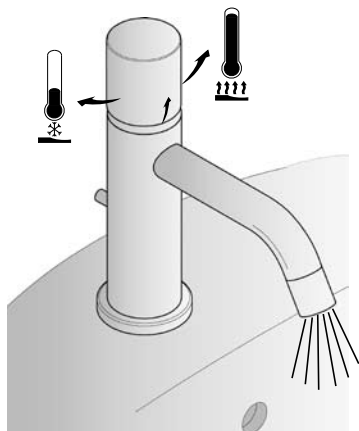



Art. 90003670

- Sostituzione cartuccia
- Cartridge replacement
- Remplacement de la cartouche
- Auswechseln der Kartusche
- Sustitucion del cartucho

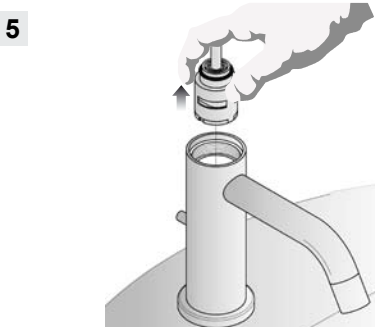
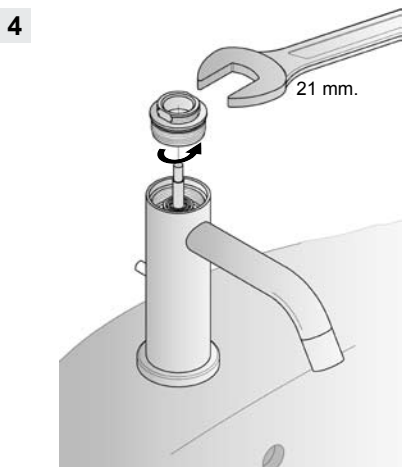
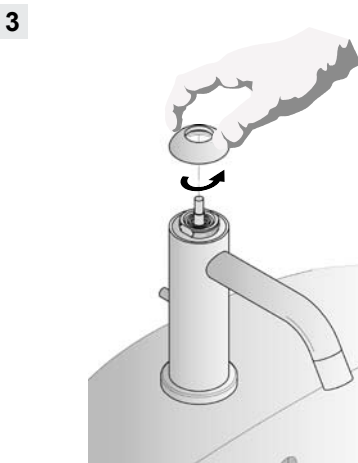
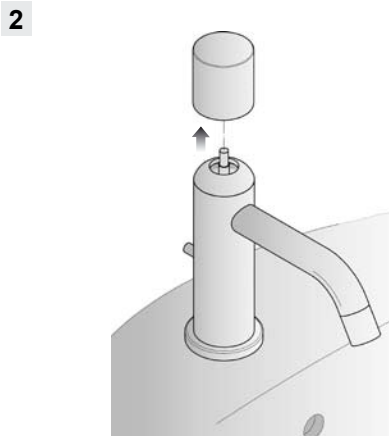
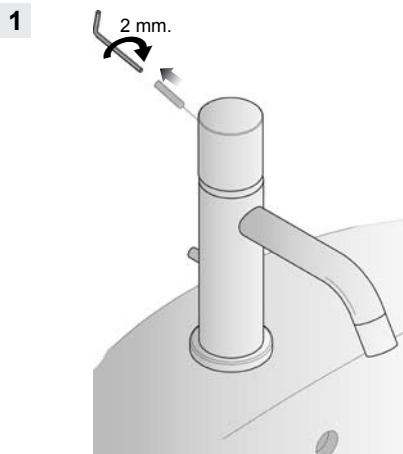

- Rimontare seguendo il procedimento inverso (5-4-3-2-1)
- Replace following the instructions in reverse order (5-4-3-2-1)
- Re-installer au contraire du procédé (5-4-3-2-1)
- Die umgekehrte Vorgehensweise folgen um die Teil wieder zu installieren (5-4-3-2-1)
- Colocar según el procedimiento inverso (5-4-3-2-1)

Installazione / Installation.

Sostituzione aeratore / Substitute aerator / Remplacement de l'aérateur / Den Lüfter auswescseln /
Sustituir el aireador

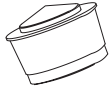

ART. 90009252 Per art. 2804F-2804WF-2808F-2803F-2803WF-2807F-2807WF
Sostituzione aeratore / Substitute aerator / Remplacement de l'aérateur
Den Lüfter auswechselln / Sustituir el aireador

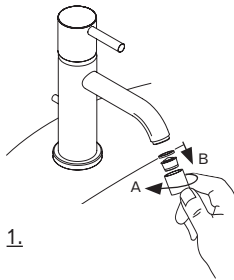

Rimontare seguendo il procedimento inverso (B-A)
Replace following the instructions in reverse order (B-A)
Re-installer au contraire du procédé (B-A)
Die umgekehrte Vorgehensweise folgen um die Teil wie der zu installieren (B-A)
Colocar según el procedimiento inverso (B-A)